

Sept 2000



# Knox & District Woodworkers Club

45 Glenfern Road, Ferntree Gully 3156

Web Site: <http://www.alchester.com.au/kdwc>

## INGRAINED

**H**elen Akerstrom, a representative of Frame Co. Pty Ltd, the Guest Speaker for the August Meeting, gave a very interesting talk on picture frame-making and the tools needed to hang a picture or photograph, and, how they are used. The Jig for cutting Oval Mounts was especially interesting.

The 'Be-in-It' Competition, held on Sunday, 13th August, was a great success and well supported. The standard of work is improving each year, which is very encouraging. Congratulations to all the winners and thank you to all those who exhibited items. Thank you also to those Members and Ladies who brought along such a delicious Afternoon Tea. A big 'Thank You' also, to those Members who helped in the setting up and cleaning up afterwards. It is much appreciated.

As Members can see by the Membership renewal sheet on the front of this Newsletter, the Committee have increased the Annual Membership Fee for the coming year to \$40. The last increase in fees was in 1995. This increase is covered by Item 8a of the Club Constitution. With the cost of equipment repairs and replacements, etc and the enhanced Club facilities, I feel that this is a fair increase, when compared with, say, a six week course at T.A.F.E.

*(continued on next page)*

This year's subscription, of course, will have a Late Payment Fee imposed, as unanimously legislated by the assembled Club Members at the March General Meeting. The conditions are as stated in the Club Standing Order Number 9, as repeated below :-

9. Payment of Annual Fees must be made by October 31<sup>st</sup>. After this date the following penalties for late payment shall be imposed :-

Over 1 month but less than 2 months	\$10.00
Over 2 months but less than 3 months	\$20.00
3 months	Membership ceases.

Any person whose Membership has ceased under the above conditions, who subsequently wishes to rejoin, will be required to pay a Joining Fee and Membership Fee, in accordance with Standing Order No. 1.

If you are interested in helping to run the Club, the Annual General Meeting will be held on Wednesday, October 4th at 7.30 pm and all Office Bearer's positions are open for nomination.

Raffle butts for the Woodie's Raffle are slowly being returned and we have, in turn, to return them to C.V.W.C., as the winning tickets will be drawn at the 'Working With Wood Show', taking place at the week-end of 27th to 29th of October. So please return your ticket if you have not yet done so. Helpers are needed by C.V.W.C. for this Show, so if you are available, please see me

If anybody happens to have a router cutter in their possession, by mistake, please Return it to the Club, as we are a couple of router cutters short. Thank you.

We are pleased to see Jim Gay out and about again after his recent operation.

Safe Woodworking.

*Dave Howell*

President

## ROSTER FOR SATURDAY MORNINGS: 9-30pm – 12-30pm

*Members Please Note: If no members have arrived by 10-15am the Key Holder has the option of closing the Clubrooms*

DATE	NAME	PHONE NO.
<b>Year 2000:</b>		
September 2 <sup>nd</sup>	Earl Webb	9801 4142
9 <sup>th</sup>	Jan Brown	9762 1063
16 <sup>th</sup>	WARRAGUL CLUB IS VISITING US	
23 <sup>rd</sup>	Christine Smith	9729 6515
30 <sup>th</sup>	Reinier Lolkema	9754 4567
October 7 <sup>th</sup>	Jan Brown	9762 1063
14 <sup>th</sup>	Doug Dell	9729 1886
21 <sup>st</sup>	STRINGY BARK FESTIVAL – Clubrooms closed	
28 <sup>th</sup>	Earl Webb	9801 4142
November 4 <sup>th</sup>	Reinier Lolkema	9754 4567
11 <sup>th</sup>	Jan Brown	9762 1063
18 <sup>th</sup>	Doug Dell	9729 1886
25 <sup>th</sup>	Chris Smith	9729 6515
December 2 <sup>nd</sup>	Earl Webb	9801 4142
9 <sup>th</sup>	Reinier Lolkema	9754 4567
16 <sup>th</sup>	Jan Brown	9762 1063
<b>Year 2001:</b>		
January 13 <sup>th</sup>	Doug Dell	9729 1886
20 <sup>th</sup>	Chris Smith	9729 6515
27 <sup>th</sup>	Earl Webb	9801 4142
February 3 <sup>rd</sup>	Reinier Lolkema	9754 4567
10 <sup>th</sup>	Jan Brown	9762 1063
17 <sup>th</sup>	Doug Dell	9729 1886
24 <sup>th</sup>	Chris Smith	9729 6515

## Quick tapers on the tablesaw

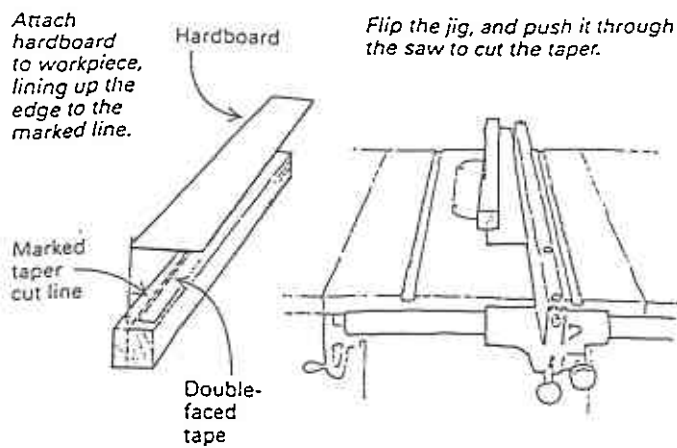

Here's a quick and foolproof way to cut tapers. First draw the desired cut line on the workpiece in pencil. Set the saw fence to a width slightly greater than the workpiece, and cut a scrap of hardboard to this width. Using either double-faced tape or tacks, affix the hardboard to the workpiece, carefully aligning the edge of the hardboard to the pencil line. Run this assembly through the saw without resetting the fence.

The saw will cut a precise taper, right to the line.

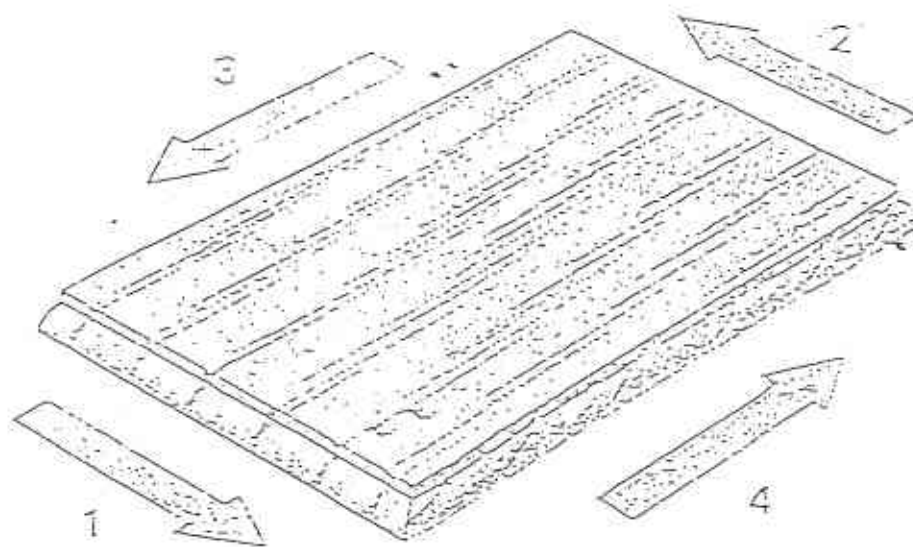

Avoiding tearout: Tearout generally occurs at the end of a cross-grain cut because the fibers at the end of the cut are not supported. If you rout across the grain first, tearout can be routed away with the long-grain cuts.

## COMING EVENTS

- September 6<sup>th</sup> Monthly meeting. Doug Camps will be demonstrating woodturning a toy
- September 14<sup>th</sup> Club's visit to MAKITA
- September 16<sup>th</sup> Warragul Club is visiting us
- October 4<sup>th</sup> Annual General Meeting
- October 21<sup>st</sup> – 22<sup>nd</sup> Stringybark Festival
- October 27<sup>th</sup> – 29<sup>th</sup> 'Working With Wood' Show

# Executive Committee 1999/2000

President .....	David Howell .....	9874 6757
Vice President .....	Peter Sleeman .....	9758 1390
Secretary .....	Fred Moore .....	9758 2207
Acting Treasurer.....	Doug Dell .....	9729 1886
Committee Member .	Bruce Allen .....	9754 5774

## General Meetings

1st Wednesday of each Month, commencing at 7.30 pm

## Workshop Hours

Monday	6.30 pm - 8.30 pm	Bill Longden	8758 2438
Tuesday	10.00 am - 3.00 pm	Peter Sleeman	9758 1390
	6.30 pm - 8.30 pm	Bruce Allen	9754 5774
Wednesday	10.00 am - 3.00 pm	Peter Sleeman	9758 1390
	6.30 pm - 8.30 pm	David Howell	9874 6757
Thursday	10.00 am - 3.00 pm	Paul Aminde	9758 1733
Friday	6.30 pm - 8.30 pm	Bruce Allen	9754 5774

Saturday

## Newsletter Editor

Tom Coghlan ..... 9801 8498



# Knox & District Woodworkers Club

45 Glenfern Road, Ferntree Gully 3156

Web Site: <http://www.alchester.com.au/kdwc>

## Invoice

Your Annual Membership Fee is now due and payable by October 31st 2000, in accordance with Standing Order No. 9.

The Annual Fee Has been increased to \$40, as determined by the Executive Committee during the Committee Meeting of August 14th 2000, in accordance with Article 8 of the Club Constitution. Standing Order No. 13 has been altered accordingly.

If you are submitting your Fee by post, would you please sign this form and return it with your payment.

Name .....

Date .....